

**PLANT VIEW  
VISTA SUPERIOR**

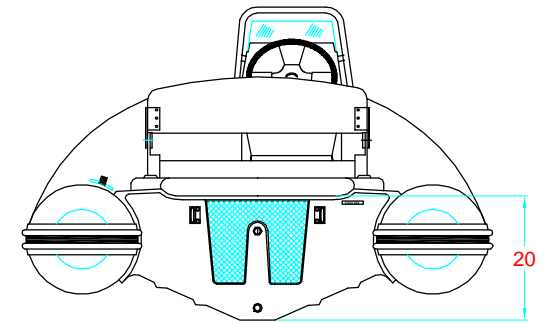

**AFT VIEW  
VISTA TRASERA**

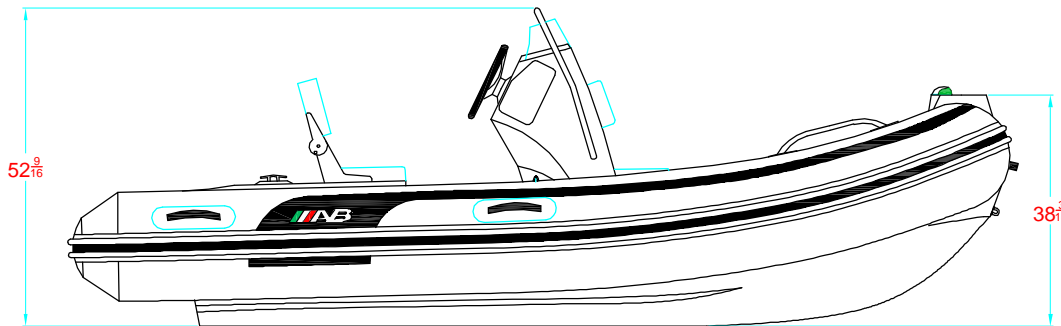

**LONGITUDINAL PROFILE  
VISTA LATERAL**

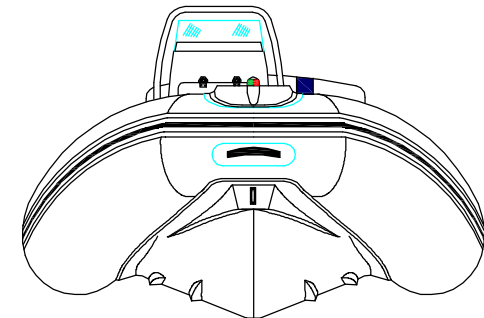

**FORE VIEW  
VISTA FRONTAL**

**MAIN PARTICULARS**

MAXIMUM LENGHT/ESLORA MAX. \_\_\_\_\_ 13' (3.96m)  
 MAXIMUM BEAM/MANGA MAX. \_\_\_\_\_ 6' 4" (1.93m)

NOTES: 1.-ALL DIMENSIONS IN INCHES  
 TODAS LAS MEDIDAS ESTAN DADAS EN PULGADAS

SUBJECTED: <b>ALEXANDER BARRIOS</b>		TITLE: <b>"OCEANUS 13 VST "</b> <b>GENERAL ARRANGEMENT</b> <b>ARREGLO GENERAL</b>						
								DATE <b>09.07.14</b>
APPROVED: <b>HERMES GARCIA</b>		SCALE.	SHEET: <b>1/1</b>	CODE:	PLAN: <b>ARTIGI.13 VST</b>	No.REV <b>3</b>	DATE	APPROVED: