

**PLANT VIEW
VISTA SUPERIOR**

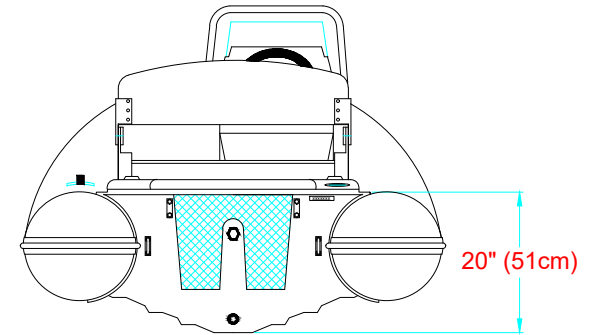

**AFT VIEW
VISTA TRASERA**

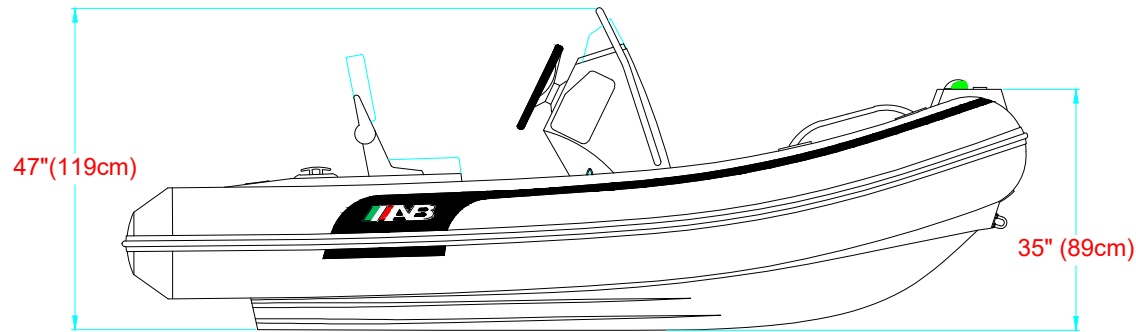

**LATERAL PROFILE
VISTA LATERAL**

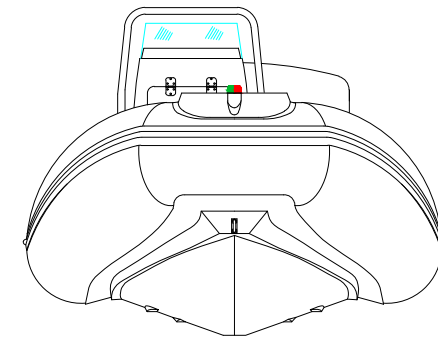

**FORE VIEW
VISTA FRONTAL**

MAIN PARTICULARS

MAXIMUM LENGHT/ESLORA MAX. _____ 11' (3.35m)
 MAXIMUM BEAM/MANGA MAX. _____ 5' 8" (1.73m)

NOTES: 1.-ALL DIMENSIONS IN INCHES & CENTIMETERS
 TODAS LAS MEDIDAS ESTAN DADAS EN PULGADAS Y CENTIMETROS

		TITLE: "OCEANUS 11 VST " GENERAL ARRANGEMENT ARREGLO GENERAL					
SUBJECTED: JAIRO MARTINEZ		SCALE:	SHEET: 1/1	CODE:	PLAN:		
APPROVED: HERMES GARCIA							DATE APPROVED: